

USER MANUAL

CAP2500 / CAP2300

Universal automatic headlight tester
Passenger cars & Trucks



1130, rue des Marels
34 000 MONTPELLIER France

Tél : (33) 04-67-156-156
Fax : (33) 04-67-224-224
e-mail : contact@capelec.fr

www.capelec.fr

SOMMAIRE

I. Introduction	2
II. General description	3
2.1 Visualization screen	3
2.2 User interface	3
2.3 Main functions	4
2.4 Tester power supply	4
III Headlight tester positioning	6
3.1 Vehicle preparation	6
3.2 Vehicle longitudinal axis positioning with laser	7
3.3 Vehicle longitudinal axis positioning with mirror	8
3.4 Optical head positioning in front of the headlamp	9
IV. Vehicle inspection	11
V. Adjustment functions	13
5.1 Dipped headlight adjustment function	13
5.2 High beam adjustment function	14
5.3 Fog light adjustment function	14
VI. Configuration	16
VII. Tester maintenance	23
VIII. Technical characteristics	24

I. Introduction

We thank you for acquiring the headlight tester CAP2500 or CAP2300. This tester takes advantage of the most advanced technologies, designed and patented by CAPELEC. The CAP2500 or CAP2300 is a standalone device for controlling and adjusting any type of headlamp.

This manual explains how to use the CAP2500 and CAP2300 in its various versions:

- CAP2500 Bluetooth
- CAP2500 Wifi
- CAP2500 RS232
- CAP2300 RS232

Please read this manual carefully before operating the device, in order to get the full benefit of it. Keep it in a safe place to consult it when necessary.

Remark : Information contained in this document are subject to change without prior notice. CAPELEC will not be held responsible in any case for any damage, direct or indirect, of any kind whatever, nor for losses or expenses, resulting from improper use.



WARNING

The lens of the system must never be exposed to sunlight.
The concentration of sunlight can cause heating and a risk of damaging the equipment and/or burns.

II. General description

2.1 Visualization screen

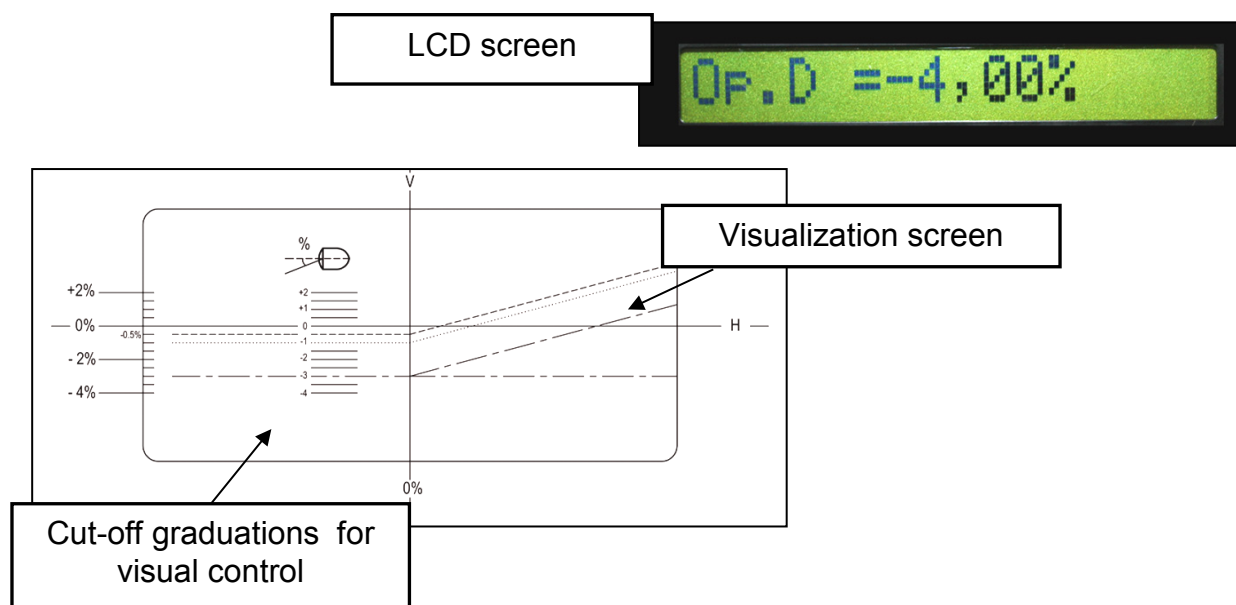

2.2 User interface



The battery light indicates, when blinking, that the battery level is low. On CAP2500, when the rechargeable batteries are in charge, the light remains on. On CAP2300, when the non-rechargeable battery is low, please replace it.



The key « On/Off » enables to switch on the tester. To switch it off, press the key 3 seconds.



The key «Print-out» enables to print out or to send measurements.



The key «Ok» enables to validate.



The key «ESC» enables to get out of a menu.



The arrows « up » and « down » enable to move in the menus.

2.3 Main functions

5 main modes are available when the tester is on:

Menu 1: Vehicle Inspection

The menu Vehicle Inspection enable to carry out dipped headlamps cut-off control (and fog lights as an option). Test results could be forwarded to a PC through the GIEGNET protocol. It is also possible to print-out the results.

Menu 2: Dipped headlamps adjustment

This function enables to carry out dipped headlamps adjustment. It enables a vertical adjustment complying with the cut-off wished by the operator. It enables a lateral adjustment at 0% only on CAP2500. Furthermore, the tester gives the light intensity and dazzling default provided by the dipped headlamp.

Menu 3: High beam adjustment

High beam adjustment enables to adjust these lamps at 0%, both lateral and vertical. The operator is guided to carry out his adjustment thanks to direction arrows. Furthermore, the light intensity of the high beam is displayed on the screen.

Menu 4: Fog light adjustment

This mode displays the cut-off measured on fog lights so that the operator can make an adjustment with an optimal cut-off.

Menu 5: Configuration

This menu gives access to several sub-menus enabling to parameter the various functionalities of the CAP2500 and CAP2300, such as the print-out mode choice, the date and time setting, the contrast adjustment, etc.

2.4 Tester power supply

CAP2300

The CAP2300 is provided with R14 C-type non-rechargeable batteries.

Remark: Deactivation of backlight enables to multiply by 3 the tester autonomy.

ATTENTION: Do not try to recharge the CAP2300 batteries.

CAP2500

The CAP2500 is provided with R14 C-type rechargeable batteries.

Remark:

Deactivation of backlight enables to multiply by 3 the tester autonomy.

When the batteries are empty, the battery light starts to blink. You must then charge them again. Connect on the rear plug of the tester the 9V charger supplied by CAPELEC.



Battery charge is shown through continuous lighting of the battery light. When the light is off, the batteries are charged and then you can disconnect the charger.

Remark about the charger:

Disconnection device is the adapter block. Therefore, it must remain accessible.

You must not use in any case another charger than the one supplied by Capelec.

CAP2500 & CAP2300

Remark on the batteries:

Battery replacement must be done with original parts.

Battery rejection :

Get rid of the batteries according to laws and regulations into effect in your own country. Do not throw used batteries in your dust bin : in most of the countries, it is forbidden by law to incinerate them, to bury them or to throw them away in rubbish dumps.

Please contact local authorities for further information on measures taken in your country to collect, recycle and destroy used batteries.

III Headlight tester positioning

3.1 Vehicle preparation

First of all, control the tyre pressure. If it is not correct, reinflation or deflation will be done to reach the recommended pressure within -0 bar and $+0.3$ bar limits. In every case, this pressure must be balanced.

Move forward the vehicle at low speed, let it stop smoothly (without using the parking brake) on a levelled and horizontal surface, front wheels in a straight line. By default, it is suitable that the vehicle runs for at least 1 wheel turn (without any effort for the trains) and to stop it (without using the parking brake) on a levelled and horizontal surface.

For vehicles with non standard suspension (e.g. : servo suspension), it is necessary to run the engine before making any measurement, wait for the vehicle to stabilize with the engine running.

Actuate the parking brake (gradually for manual handbrakes).

When the vehicle is equipped, either in the passenger compartment or at the headlamp level, with a manual setting system, place the device in the position recommended by the manufacturer according to the charge state. If the system does not work, the control is made in the existing configuration.

3.2 Vehicle longitudinal axis positioning with laser

1- Move forward the headlight tester in front of the centre of the vehicle so that the headlight tester lens is within 20 and 50 cm from each headlamp (optimal distance being 35cm).

2- Identify on the vehicle 2 fixed marks, symetrically spread out with regard to its central axis (examples : right and left upper windscreen angles, non distorted engine bonnet angles, windscreen washer jets if their support is not distorted).

3- Make the optical head swivel so that the laser line match with the marks identified on the vehicle.

4- You can start with the control or adjustment procedure. During this phase you will move the headlight tester in front of the headlamp to be controlled or adjusted while keeping the angular positioning carried out with the laser.

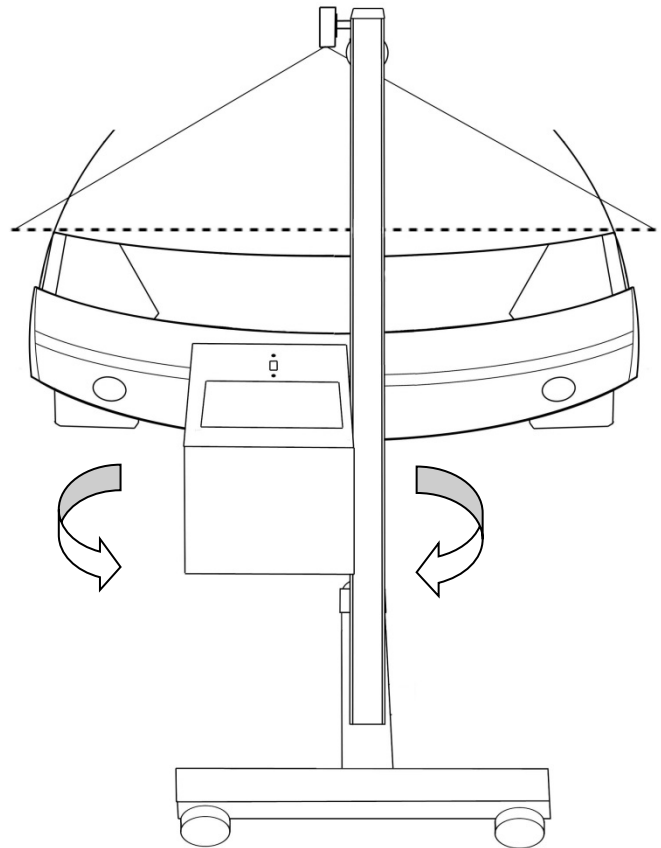

WARNING Laser radiation:

- Class 2M laser device
- Do not look directly into the beam nor directly observe using "magnifying" optical instruments.
- The vehicle must be empty of occupants when the laser beam is being adjusted.
- Laser adjustment must be used momentarily.

3.3 Vehicle longitudinal axis positioning with mirror

1- Move forward the headlight tester in front of the centre of the vehicle so that the headlight tester lens is within 20 and 50 cm from each headlamp (optimal distance being 35cm).

2- Identify on the vehicle 2 fixed marks, symetrically spread out with regard to its central axis (examples : right and left upper windscreen angles, non distorted engine bonnet angles, windscreen washer jets if their support is not distorted).

3- Make the optical head swivel so that the mirror line match with the marks identified on the vehicle.

4- You can start with the control or adjustment procedure. During this phase you will move the headlight tester in front of the headlamp to be controlled or adjusted while keeping the angular positioning carried out with the laser.

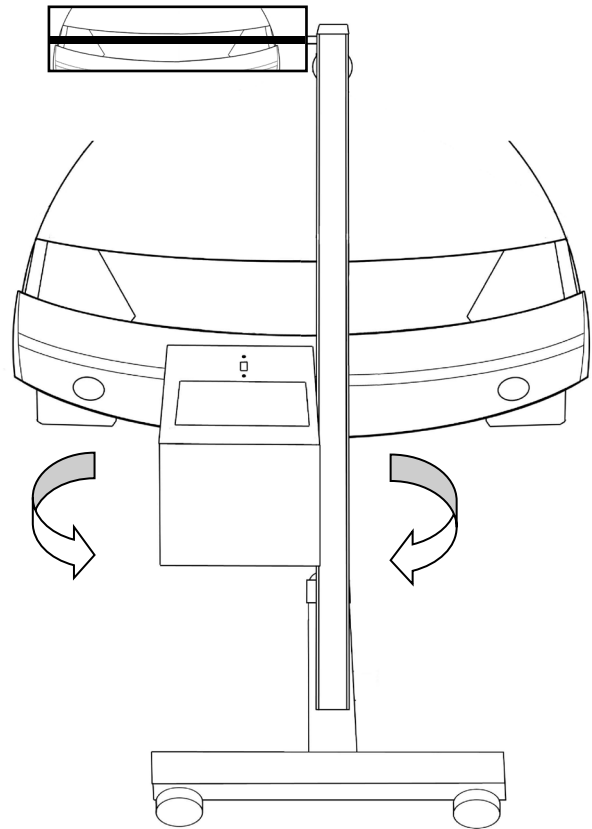

3.4 Optical head positioning in front of the headlamp.

Electronic positioning assistance (only available on CAP2500) allows you to be guided when positioning the optical head in front of the headlamp. It activates itself before each cut-off measurement for dipped headlamps. Indications displayed on the screen tell you in what direction to move the head. When the optimal positioning is reached, « Ok » is displayed on the screen, and the testers goes automatically to the next step.

Operating mode for CAP2500:

1- Move the headlight tester in front of the headlamp to be controlled, by visually positioning it below the headlamp centre.

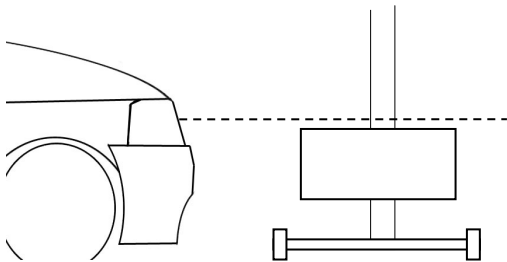



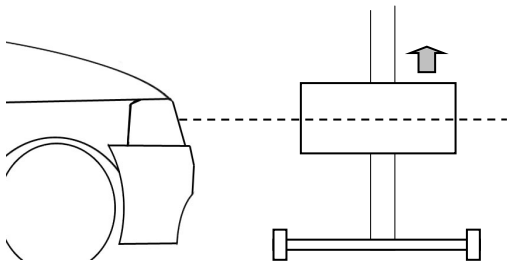

2- Follow the indications on the screen, so that to move up the optical head at the right height.

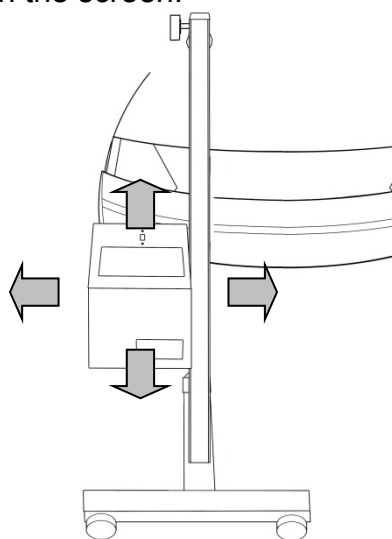

3- At last, position accurately the optical head by taking into account the indications until you get « Ok » on the screen.



-  Up
-  Down
-  Forward
-  Backwards

Position: ►►OK◄◄

ATTENTION: During this operation, you must be sure that the front side of the tester is not exposed to external light interference (sun, spot light), which could change the positioning.

Visual positioning for CAP2300 or CAP2500:

If the positioning assistance is not available on your tester, manual positioning is done by placing face-to-face the lens centre and the headlamp centre as well.

1- First, position laterally the optical head in front of the headlamp

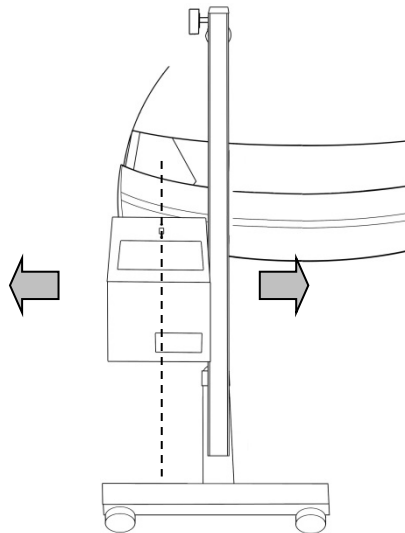

2- Measure the headlamp centre height and position the lens centre at this level.

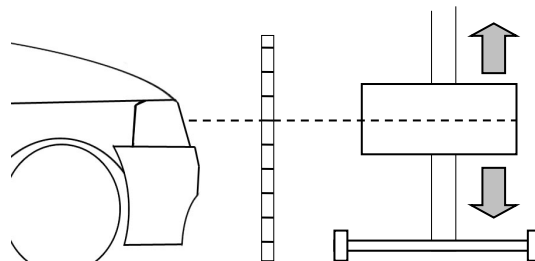

IV. Vehicle inspection

In the menu 1 « Vehicle Inspection », the headlight tester will assist you along the vehicle headlamp control. All the steps proposed by the tester will be described in the hereafter chapter.

Vehicle selection

GIEGNET Mode: vehicle number plate selection.

Connection with the PC of the station allows you to access to the number plate list of vehicles to be controlled. First step is to select the vehicle number plate that you want to control.



Validate your selection by pressing the key « Ok ».

Printer: vehicle number plate acquisition.

First step is to acquire the vehicle number plate to be controlled. Press keys « up » and « down » to scroll numbers and letters to acquire and press « Ok » to go the next letter. Once the number plate is acquired, press « Ok » until the cursor reaches the end of the line. Then, you can go ahead to the next step.



To delete the number plate, if any mistake, press « Echap ».

If you do not want to acquire a number plate and proceed directly to the next step, press « Ok » when you are at step 1.

Dipped headlamps

First of all, please position the headlight tester in front of the first headlamp to be controlled (See chapter «Headlight tester positioning»).

Remark: If the « Positioning assistance » is available, the tester will tell you how to move the optical head so that to reach the optimal position for the control.

During the measurement phase, the tester tells you which headlamp you are controlling (right or left) and the cut-off of this one in % and light intensity in lux or kcd.

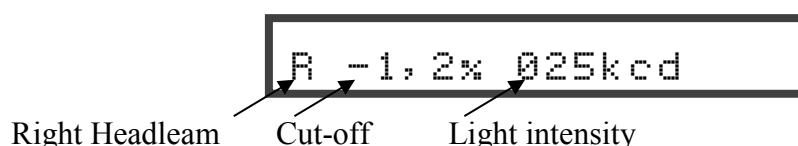

High beam

As did previously, you have to:

- define the high beam light height to be controlled,

- position the tester,
- then successively control, right and left beam. The tester tells you the headlamp to be controlled, the high beam hot spot position with arrows and light intensity in lux or kcd.

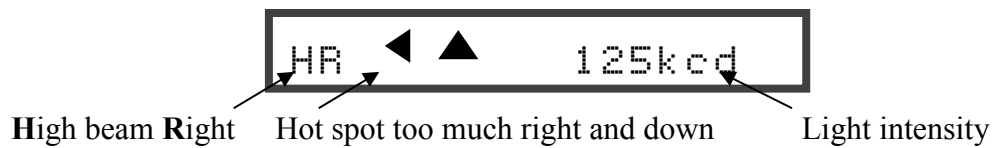

Fog light

As did previously, you have to:

- define the fog light height to be controlled
- position the tester (« Positioning assistance » is not available with fog light function)
- then successively control, right and left beam. The tester tells you the headlamp to be controlled and cut-off measured in % and light intensity in lux or kcd as well

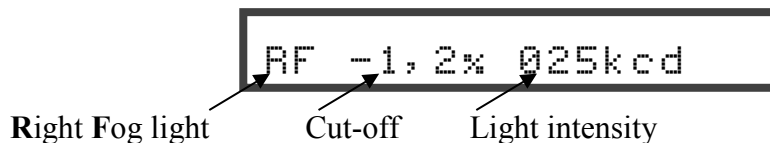

Test result



Vehicle inspection is now complete.



You can visualize your measurement results by pressing on arrow .

GIEGNET mode:

To send the measurements, press key .

In case there is a problem in the transmission of the measurements, you can access to the print-out mode by pressing on arrow . Thus, by validating on  you launch the print-out of your results on a printer.

Print-out mode:

To send your results, switch on the printer and press key .

V. Adjustment functions

5.1 Dipped headlight adjustment function

This function allows the operator to carry out a lateral and vertical adjustment of dipped headlights. This operation is done in the following way:

Positioning

First of all, you must position the headlight tester in the front of the headlamp to be adjusted (See chapter “Headlight tester positioning”).

Remark : If the « Positioning assistance » is available, the tester will tell you how to move the optical head so that to reach the optimal position for the control.

Vertical adjustment

Adjust the headlamp to the cut-off that you want to obtain, by following the cut-off value displayed on the screen.

Cut: -1,22%

The adjustment optimal value is generally indicated on the headlamp housing. On the contrary, the cut-off to apply is $R(\%) = 2 \times h(m)$, h being the headlamp optics centre height.

Lateral hot spot adjustment (function not available on CAP2300)

Adjust laterally the headlamp by following the indications of the arrows on the screen and try get the indicator value to “0”.

Lat: ←← 65

Dipped headlight hot spot must go left Indicator value

When “OK” is display on the screen, the headlamp is correctly laterally adjusted.

Lat: >>OK<<

Light intensity and dazzling diagnostics

→ 085kcd Daz / OK

Light intensity in kcd or Lux

OK = Dazzling is ok / PB = Dazzling problem

5.2 High beam adjustment function

Positioning

First of all, you must position the headlight tester in the front of the headlamp to be adjusted (See chapter “Headlight tester positioning”).

Remark : If the « Positioning assistance » is available, the tester will tell you how to move the optical head so that to reach the optimal position for the control.

Lateral and vertical hot spot adjustment

Important When you adjust dipped headlights or high beam in the same optics, the priority must be given to the dipped headlights adjustment : an offset may exist due to the position of the filaments in the bulb.

This function allows the operator to make both lateral and vertical adjustment of high beam. First of all, you must carry out positioning of the CAP2500 in front of the headlamp to be adjusted (See chapter IV).

Adjust laterally and then vertically the headlamp by following the indications of the arrows on the screen.



Hot spot must go left

Hot spot must go up

When « Ok » is displayed on the screen, the headlamp is correctly adjusted.



Light intensity diagnostics



Light intensity in kcd or Lux

5.3 Fog light adjustment function

Positioning

First of all, you must position the headlight tester in the front of the headlamp to be adjusted (See chapter “Headlight tester positioning”).

Remark:

The « Positioning assistance » is not available with fog light function.

Vertical adjustment

The fog light adjustment function gives you the beam cut-off on the screen. Only vertical adjustment has to be done. The fog lights must be adjusted 1% below dipped headlights.

Cut: -2,51%

For example, dipped headlights adjusted at -1.5% imply a fog light adjustment at -2.5%.

Light intensity diagnostics

125kcd

Light intensity in kcd or Lux

VI. Configuration

This menu gives access to different sub-menus enabling to parameter the tester.

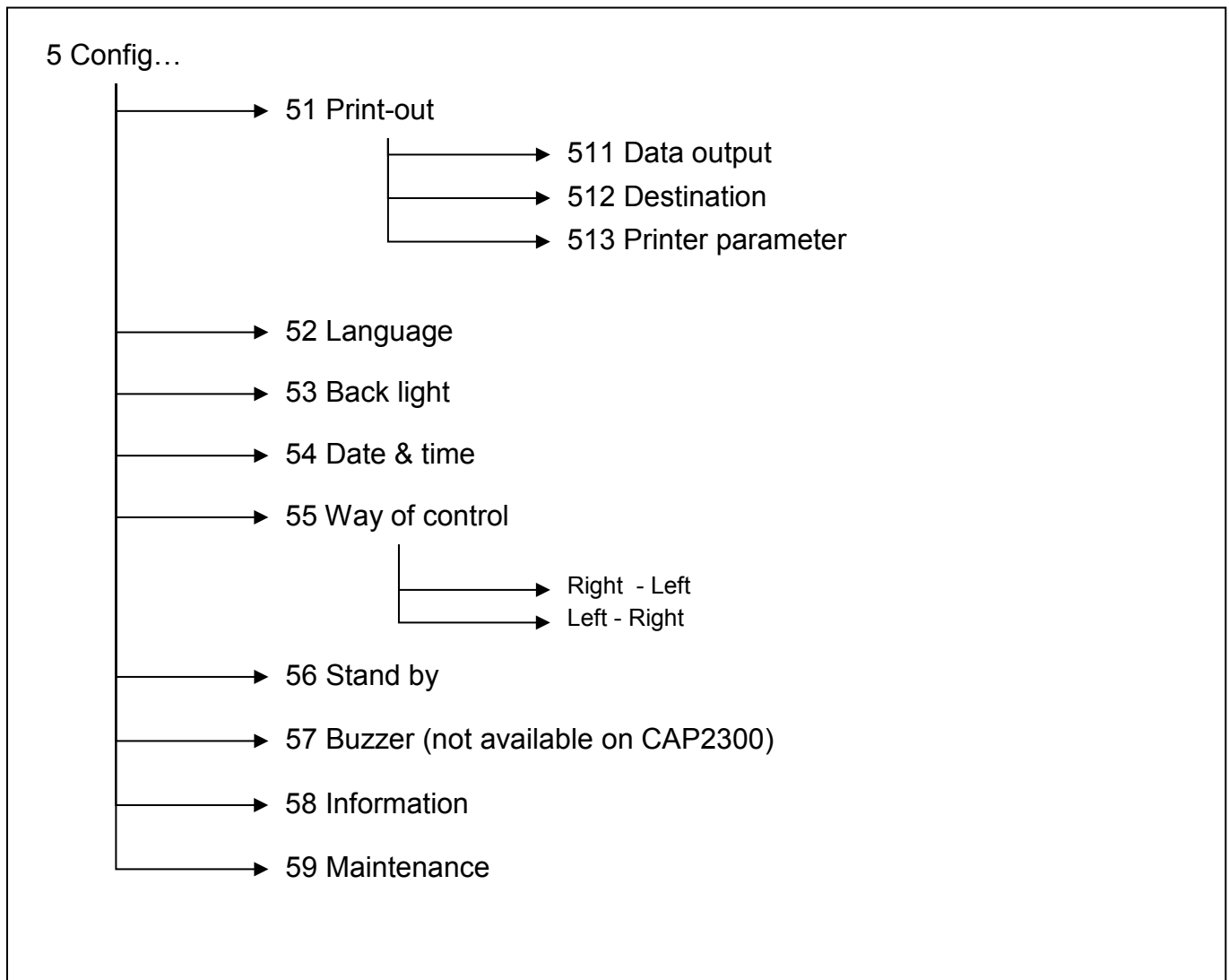

6.1 Print-out sub-menu

This menu gives access to 3 sub-menus: Data output, Destination parameter, and Printer parameter. These sub-menus give access to different parameters according to your headlight tester type CAP2500 Bluetooth, CAP2500 WIFI, CAP2500 RS232, or CAP2300 RS232.

CAP2500 (Bluetooth version):

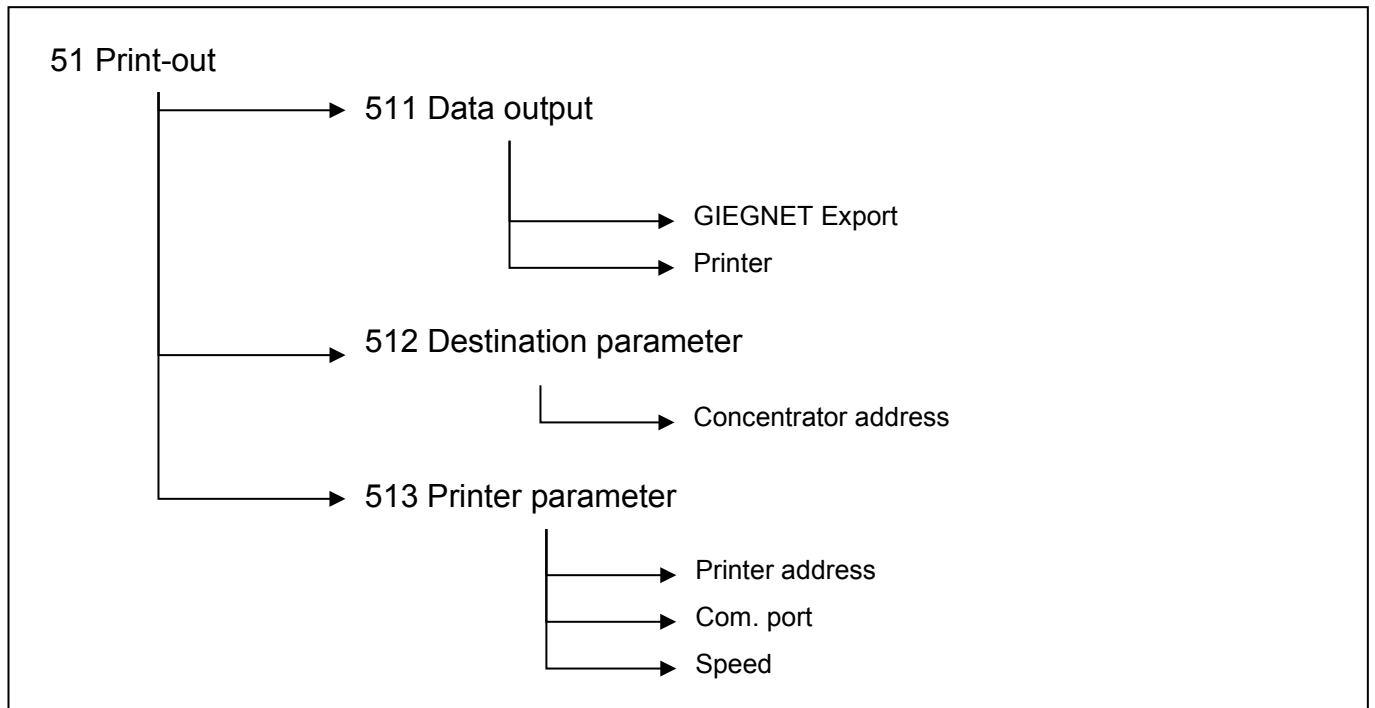

Data output sub-menu

This menu allow the operator to select between GIEGNET Export and Printer. Selection between one of these 2 modes will affect succession of the steps in the vehicle inspection procedure.

GIEGNET Export :

Enables to transfer data from the vehicle inspection to the PC of the station, or to another peripheral complying with the GIEGnet protocol.

Printer :

Enables to print out vehicle inspection data on a Bluetooth or RS232 printer.

Destination parameter sub-menu

Not used.

Printer parameter sub-menu

Printer address :

This menu allows you to acquire the Bluetooth printer address on which you want to print out your results.

Com. port :

This menu allows you to choose on which type of printer you want to print out your results, RS232 or Bluetooth.

Speed :

This menu allows you to parameter the communication speed with an RS232 printer (by default 9600 Baud).

CAP2500-WIFI :

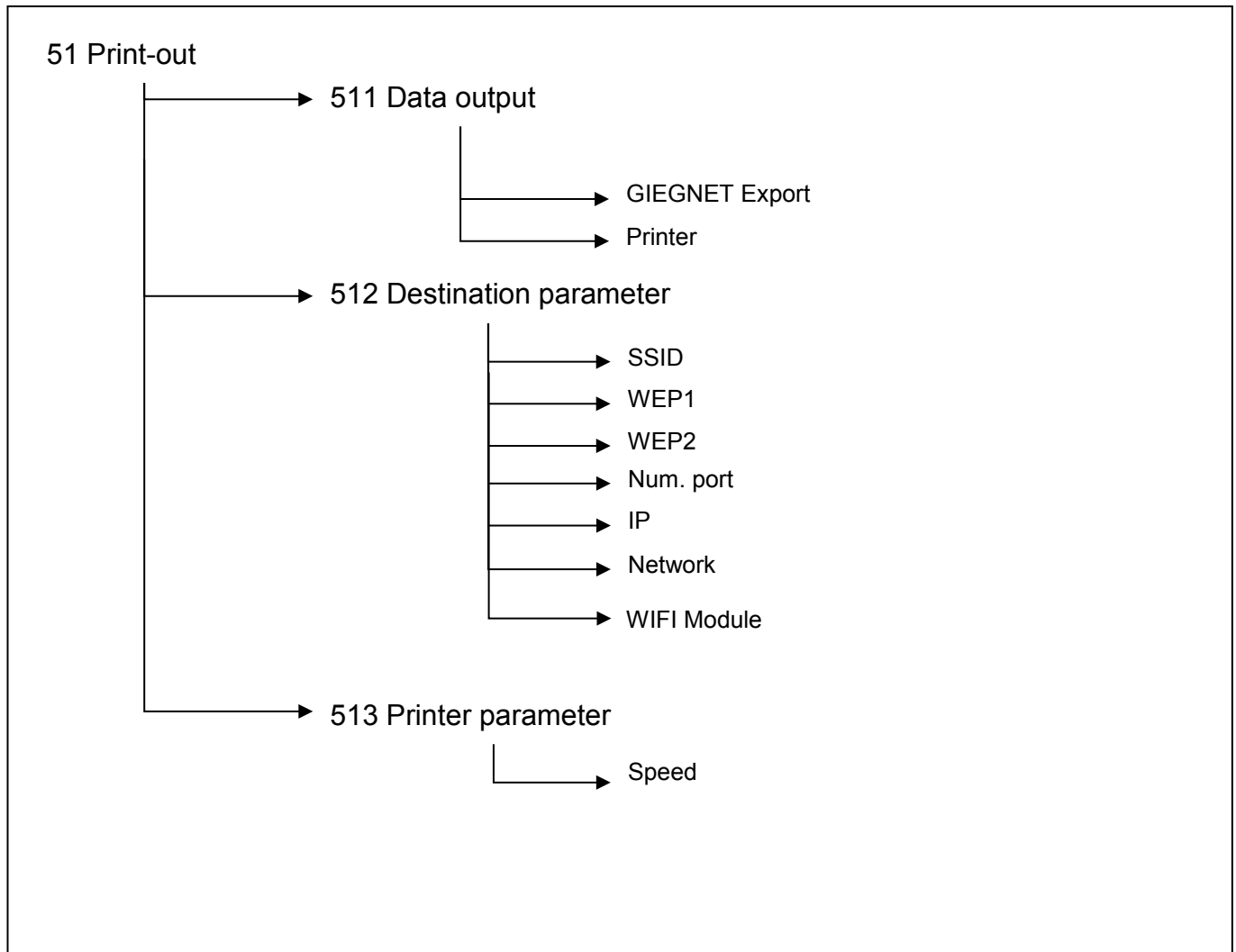

Data output sub-menu

This menu allows the operator to choose between GIEGNET Export, and Printer. Selection between one of these modes will affect succession of the steps in the vehicle inspection procedure.

GIEGNET Export:

Enables to transfer data from the vehicle inspection to the PC of the station, or to another peripheral complying with the GIEGnet protocol.

Printer:

Enables to print out vehicle inspection data on RS232 printer.

Destination parameter menu

This menu gives you access to the various network parameters in order to configure the connection at the Wifi access point.

Printer parameter sub-menu

This menu allows you to parameter the communication speed with an RS232 printer (by default 9600 Baud).

CAP2500-RS232 and CAP2300-RS232

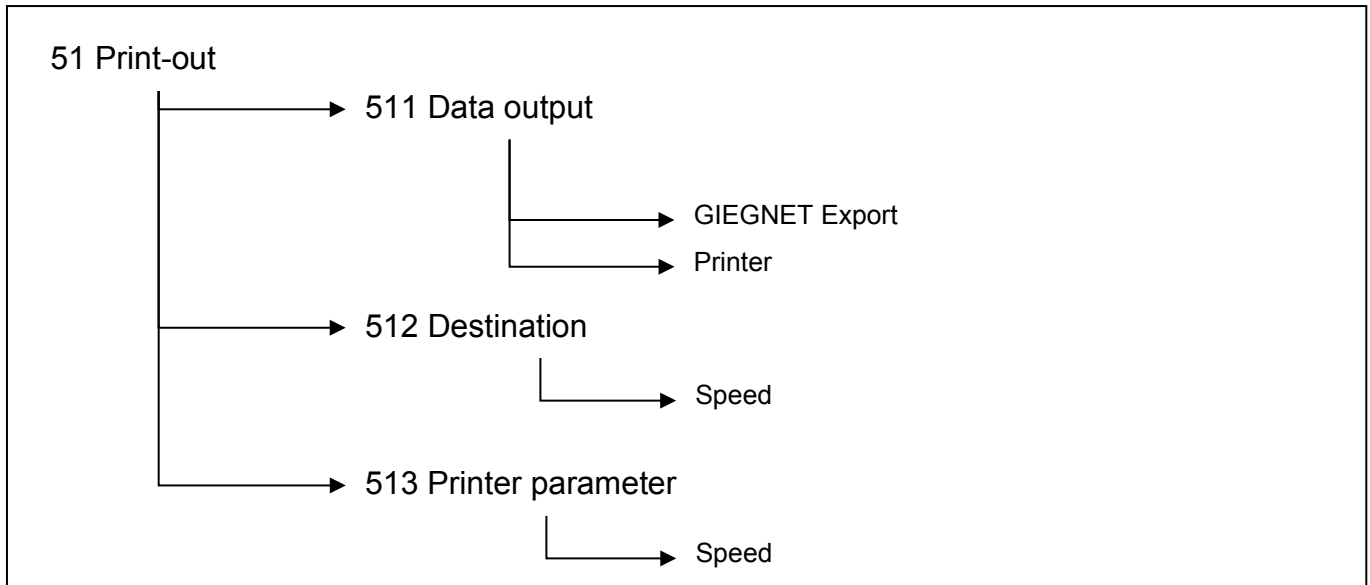

Data output sub-menu

This menu allows the operator to choose between GIEGNET Export, and Printer. Selection between one of these modes will affect succession of the steps in the vehicle inspection procedure.

GIEGNET Export :

Enables to transfer data from the vehicle inspection to the PC of the station, or to another peripheral complying with the GIEGnet protocol.

Printer :

Enables to print out vehicle inspection data on RS232 printer.

Destination parameter destination

This menu enables to parameter the communication speed between the PC in the Giegnet Export (by default the GIEGNET works in 2400 Baud)

Printer parameter sub-menu

This menu allows you to parameter the communication speed with an RS232 printer (by default 9600 Baud).

6.2 Language sub-menu

This menu gives you access to setting language.

6.3 Back light sub-menu

This menu allow you to activate or to deactivate LCD screen back light.

6.4 Date & time sub-menu

This menu gives you access to setting of date and time.

6.5 Way of control sub-menu

This menu allows you to choose the headlamp way of control in the vehicle inspection procedure. Right headlamp first, then left (right – left) and inversely (left - right).

6.7 Stand-by sub-menu

This menu enables to configure when the tester is going to automatically switch off in case of inactivity (no pressure on the keyboard keys).

6.8 Buzzer sub-menu (not available on CAP2300)

If you want it, you can deactivate the buzzer of the keyboard keys of your tester.

6.9 Information sub-menu

This menu gives you access to the following information:

- Model of the tester
- Software version
- Serial number of the tester
- Homologation
- Battery level
- Bluetooth address of the tester (if your tester is Bluetooth).

VII. Tester maintenance

Maintenance of the lens:

- Avoid to put the fingers on the lens to prevent dirtiness
- Clean it if necessary (with soapy water or with a windscreen washer product)
- If your lens is cracked or scratched too heavily you have to replace it through a service company.

Mechanical checking:

- When operating your tester, check that the bubble of the on-board level remains in its original position whatever the tester position.
- In case of the bubble deviates too much, please contact your service company in order a technician checks your tester and its calibration.

VIII. Technical characteristics

Characteristics:

- Weight : 25kg
- L x W x H : 590 x 670 x 1550 m
- Autonomy 15h on rechargeable battery in continuous operating
- Quick recharge in 3h30 with automatic stop (only with CAP2500)

Operating conditions:

- CAP2500 rechargeable batteries: 4 x rechargeable accumulator R14 C-Type
- CAP2500 Charger power supply: 9V 2A
- CAP2300 non- rechargeable batteries: 4 x cell R14 C-Type
- Ambient temperature: from 5 to 40°C
- Storage temperature: -15 to +55°C
- Relative humidity : <98% non condensed

Measurement:

- Cut-off measurement : in %
- Range of measurement : from +2 to -4%
- Accuracy : +/- 0.2%

- Light intensity measurement : in Candela or Lux
- Measurement range : 0 to 125 kcd
- Measurement range : 0 to 200 lux
- Accuracy : 10%



This symbol indicates that, in accordance with DEEE directive (2002/96/CE) and with the regulation of your country, this product should not be thrown with the household refuse. You must deposit it in a place of collecting envisaged to this end, for example, an official site of collection of the electric components and electronics (EEE) for their recycling or a terminal point of products authorized which is accessible when you acquire of a new product of the same type as the old one. Any deviation compared to these recommendations of elimination of this type of waste can have negative effects on the environment and the public health because these products EEE generally contain substances which can be dangerous. In parallel, your whole cooperation with the good reject of this product will support a better use of the natural resources. To obtain more information on the points of collection of the equipment to be recycled, contact your town hall, the service of collection of waste, approved plan DEEE or the service of garbage collection domestic.

DECLARATION UE DE CONFORMITE / EU DECLARATION OF CONFORMITY

Equipement : <i>Product:</i>	CAP2500
Fabriquant: <i>Manufacturer:</i>	CAPELEC 1130 rue des marels 34000 Montpellier FRANCE
<p>La présente déclaration de conformité est établie sous la seule responsabilité du fabricant <i>This declaration of conformity is issued under the sole responsibility of the manufacturer.</i></p>	
Objet de la déclaration : <i>Declaration object :</i>	CAP2500
<p>L'objet de la déclaration décrit ci-dessus est conforme à la législation d'harmonisation de l'Union applicable <i>The object of the declaration described above is in conformity with the relevant Union harmonization legislation</i></p>	
<p>DIRECTIVE COMPATIBILITE ELECTROMAGNETIQUE <i>ELECTROMAGNETIC COMPATIBILITY DIRECTIVE</i> 2014/30/UE (2004/108/EC)</p> <p>DIRECTIVE BASSE TENSION <i>LOW VOLTAGE DIRECTIVE</i> 2014/35/UE (2006/95/EC)</p> <p>DIRECTIVE RED 2014/53/UE (1999/5/CE)</p>	
<p>Références des normes harmonisées <i>References to the relevant harmonized standards used</i></p>	
<p>EN61010-1 :2011 EN61326-1 :2013 EN300 328-2 :2015</p>	
Signature du fabriquant : <i>Manufacturer signature:</i> CAPELEC 1130 rue des marels 34000 Montpellier FRANCE	<p>MONTPELLIER le 23/05/2016</p>  <p>Thierry COTON Gérant / General Manager</p>